

AyrJet™ by Spencer is the new American way!

Reduce energy costs on water and wastewater treatment aeration with the latest innovation in high speed, high efficiency turbo blowers.

AyrJet™
by Spencer.

AyrJet™ by Spencer provides efficient operation and significant energy savings, self-contained, plug-and-play installation and increased reliability with oil-free air delivery, significant sound reduction, and a small footprint. It is the ideal solution for energy efficient water and wastewater treatment aeration.

- Discharge pressures up to 15 PSIG
- Larger HP capacity equals fewer blowers
- Maximum wire-to-air efficiency
- Superior magnetic bearings
- User-friendly PLC and OIT
- Savings – power, space, maintenance



Save even more on energy, with help from the company that brought the water and wastewater treatment industry the Power Mizer® multistage cast centrifugal blower. The new AyrJet by Spencer is the latest in high speed, high efficiency turbo blowers. It expands Spencer's product offerings — which also include digester gas boosters and gas booster skid packages, fabricated centrifugal blowers, custom control packages, and other specialized engineered and manufactured products. Backed by full pre- and post-sale support through Spencer's U.S.-based headquarters, AyrJet incorporates USA manufactured and designed components, including motor and VFD.*

Using our innovative R&D process, with advanced in-house labs and testing facilities, Spencer technical experts developed AyrJet to meet the water and wastewater treatment latest market



requirements. With a larger HP capacity equaling fewer blowers, the product also provides best-in-industry wire to air efficiencies. Its user-friendly programmer logic controller (PLC) and operator interface terminal (OIT) offer increased flexibility with flow-based, pressure-based or level-based control. There is no proprietary control hardware, and AyrJet offers remote access to blower controls for diagnostics and troubleshooting.

AyrJet also includes superior time-tested magnetic bearing technology with high thrust load capability. It allows for unlimited starts and stops, and offers inherent "fail safe" protection, lower starting torque, higher horsepower capacity, and superior vibration management.

It's Spencer innovation, reliability, and energy efficiency blended together. No wonder AyrJet by Spencer is the new American way.

**Note: AyrJet™ installations may qualify for certain government funding and stimulus incentives as described in the American Recovery and Reinvestment Act (ARRA) of 2009.*

AyrJet by Spencer – The New American Way

The **Spencer** Turbine Company, 600 Day Hill Road, Windsor, CT 06095-4706

TEL 800-232-4321 ♦ 860-688-8361 ♦ FAX 860-688-0098 ♦ www.spencerturbine.com



TECHNICAL DATA SHEET



High speed, high efficiency turbo blower provides energy efficient air delivery

Made in the USA by The Spencer Turbine Company, the AyrJet™ Series 100 is a high speed, high efficiency single-stage turbo blower, driven by a direct drive oil-free permanent magnet motor. It has an integrated variable frequency drive (VFD) with PLC controls.

The product expands Spencer's product offerings for the water and wastewater treatment industries. With flows to 2000 CFM and pressures to 16 PSIG, it handles applications ranging to 100 HP, includes built-in vibration and temperature monitoring, and features best-in-industry wire to air efficiencies. Built-in inlet filtration is standard, and externally mounted inlet filters are available.

The AyrJet's highly engineered, proven technology magnetic bearings monitor and manage shaft position for proactive protection against catastrophic failure.

Designed especially to meet continuous-duty aeration requirements with peak energy efficiency, the AyrJet Series 100 is the ideal solution for applications in water and wastewater treatment plants.

Materials of Construction

- Casing material: Aluminum 356-T6
- Enclosure material: Carbon steel
- Finish: Powder coated

Product Features

Technical Data

Number of stages: 1
Operating speed: Up to 35,000 RPM
Casing design pressure: 50 PSIG
Inlet connection: Integrated filter (standard); pipe flange (optional)
Outlet connection: 8" flange
Seals: Teflon labyrinth seal
Bearings:
<ul style="list-style-type: none"> • Magnetic • Self-monitoring • Non-contact • 2 modes of fail safe (back-up roller bearing and auto shutdown on fault)
Lubrication: None
Impeller: Machined high strength forged aluminum – 7075-T6 alloy
Cooling system: Integrated air cooling
Filters: Nominal retention 98% @ 15 microns, 98% @ 10 microns or 95% @ 1 to 2 microns
First critical speed: 20% over maximum operating
Vibration: 0.5 mils

Control System – UL Listed

PLC based with touch-screen and interface to the plant SCADA system
<ul style="list-style-type: none"> • Blower system start/stop selection and status indicator • Blower control selection: Local or remote • Blower set-point entry (RPM/SCFM/PSI/DO) • Remote signal set point for (RPM/SCFM/PSI/DO) • Display status for: <ul style="list-style-type: none"> • Actual blower speed (RPM) and set point • Actual blower flow (SCFM) and set point • Actual blower pressure (PSI) and set point • Actual blower dissolved oxygen (DO) and set point • Integrated blow-off valve • Blower discharge pressure • Magnetic bearing • Shaft position • Motor winding temperature • VFD and alarm indicator

AyrJet by Spencer – The New American Way

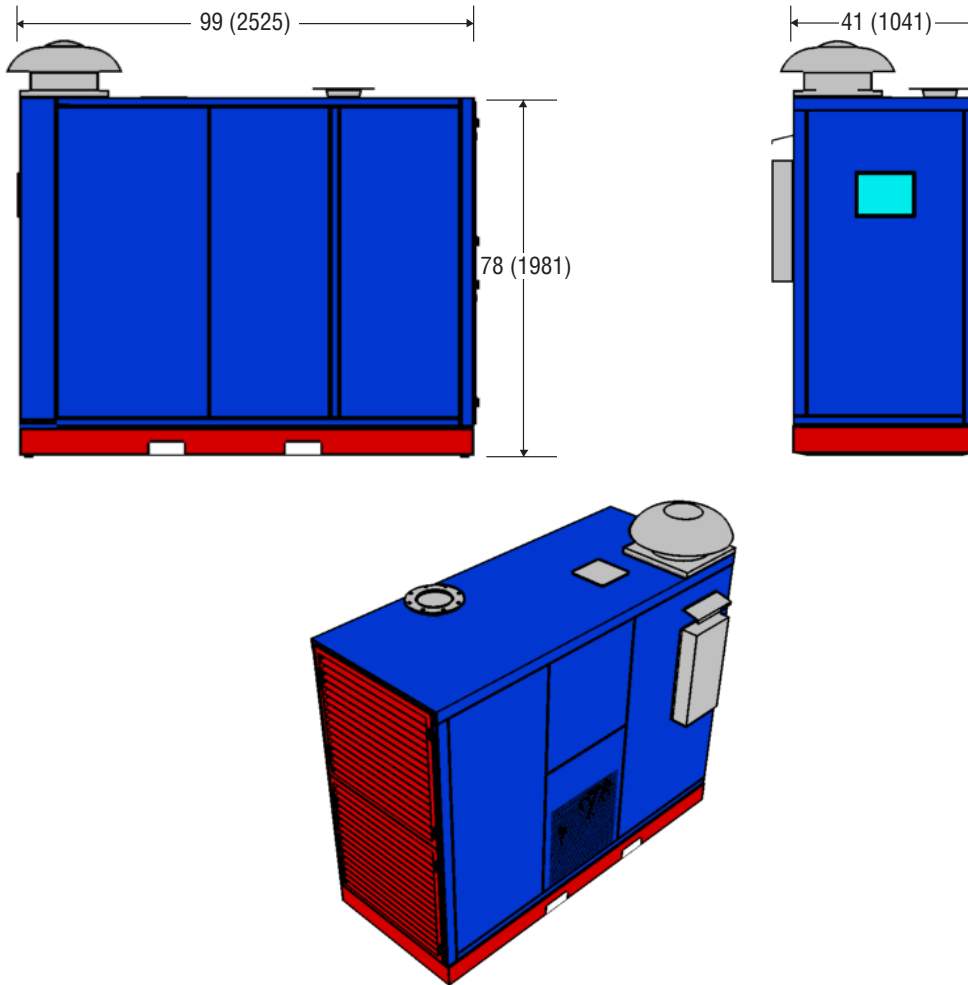

Performance Range

Performance at Standard Conditions

(Air at 68 °F, Relative Humidity of 36%, Inlet Pressure 14.7 psia)

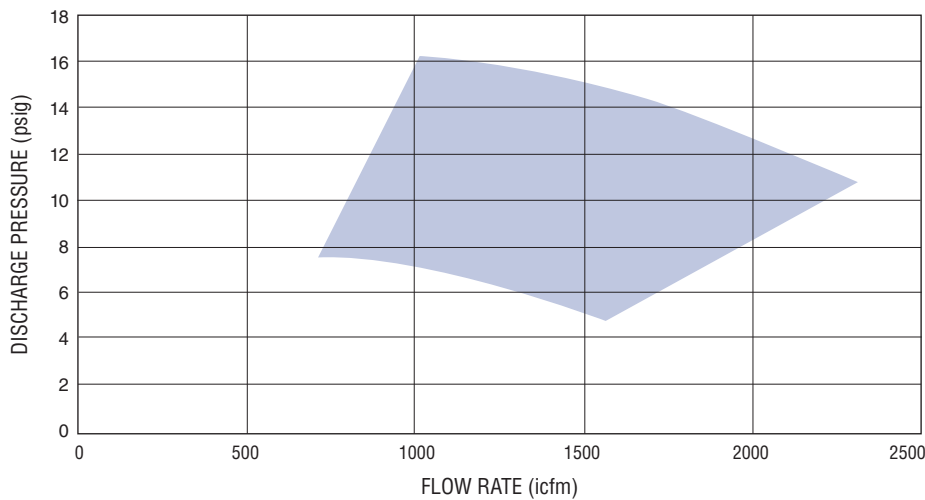

▶ Spencer may make improvements and dimensional changes to equipment designs based on market trends and requirements.

For product selection assistance, please email marketing@spencer-air.com or visit our website at www.spencerturbine.com to locate the Spencer representative in your area.



AyrJet by Spencer – The New American Way
Turbine Company, 600 Day Hill Road, Windsor, CT 06095 USA

TEL 800-232-4321 ♦ 860-688-8361 ♦ FAX 860-688-0098 ♦ www.spencerturbine.com

TDS-196 Copyright ©2012 The Spencer Turbine Company 091112KBA



TECHNICAL DATA SHEET



High speed, high efficiency turbo blower provides energy efficient air delivery

Made in the USA by The Spencer Turbine Company, the AyrJet™ Series 200 is a high speed, high efficiency single-stage turbo blower, driven by a direct drive oil-free permanent magnet motor. It has an integrated variable frequency drive (VFD) with PLC controls.

The product expands Spencer's product offerings for the water and wastewater treatment industries. With flows to 4000 CFM and pressures to 15 PSIG, it handles applications to 200 HP, includes built-in vibration and temperature monitoring, and features best-in-industry wire to air efficiencies. Built-in inlet filtration is standard, and externally mounted inlet filters are available.

The AyrJet's highly engineered, proven technology magnetic bearings monitor and manage shaft position for proactive protection against catastrophic failure.

Designed especially to meet continuous-duty aeration requirements with peak energy efficiency, the AyrJet™ Series 200 is the ideal solution for applications in municipal wastewater treatment plants.

Materials of Construction

- Casing material: Aluminum 356-T6
- Enclosure material: Carbon steel
- Finish: Powder coated

Product Features

Technical Data

Number of stages: 1
Operating speed: Up to 27,000 RPM
Casing design pressure: 50 PSIG
Inlet connection: Integrated filter (standard); pipe flange (optional)
Outlet connection: 14" flange
Seals: Teflon labyrinth impeller seal
Bearings:
<ul style="list-style-type: none"> • Magnetic • Self-monitoring • Non-contact • Built-in power failure back-up protection (UPS system) • 2 modes of fail safe (back-up roller bearing and auto shutdown on fault)
Lubrication: None
Impeller: Machined high strength forged aluminum – 7075-T6 alloy
Cooling system: Integrated air
Filters: Nominal retention 98% @ 15 microns
First critical speed: 20% over maximum operating
Vibration: 0.5 mils

Control System – UL Listed

- PLC based with touch-screen and interface to the plant SCADA system
- Blower system start/stop selection and status indicator
 - Blower control selection: Local or remote
 - Blower set-point entry (RPM or SCFM)
 - Remote signal set point for speed (RPM) and flow (SCFM)
 - Display status for:
 - Actual blower speed (RPM) and set point
 - Actual blower flow (SCFM) and set point
 - Blow-off valve
 - Blower discharge pressure
 - Magnetic bearing
 - Shaft position
 - Motor winding temperature indicator
 - VFD and alarm indicator
 - System vibration alarm indicator

AyrJet by Spencer – The New American Way

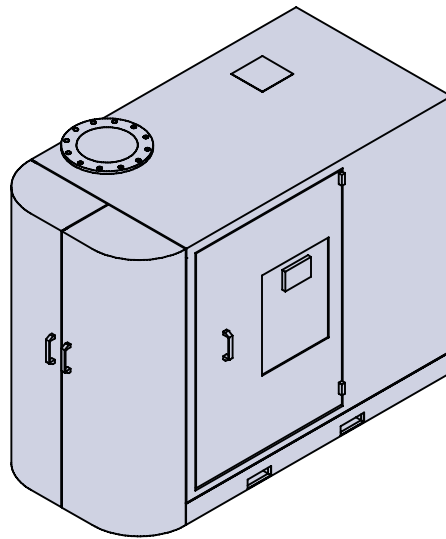
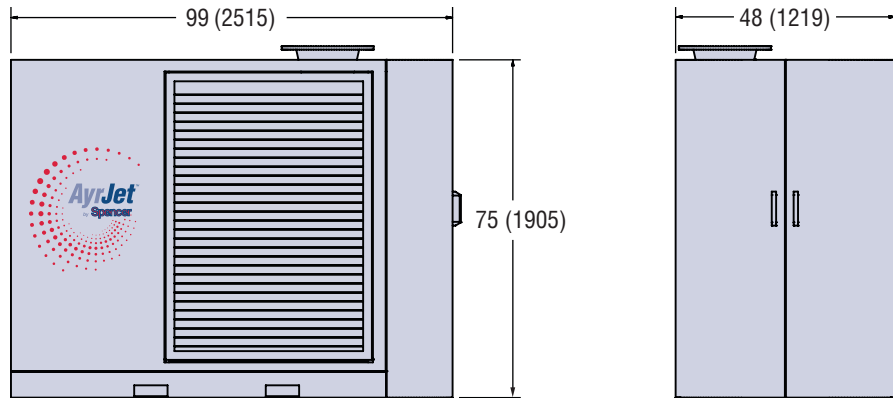

Performance Range

Performance at Standard Conditions

(Air at 68 °F, Relative Humidity of 36%, Inlet Pressure 14.7 psia)

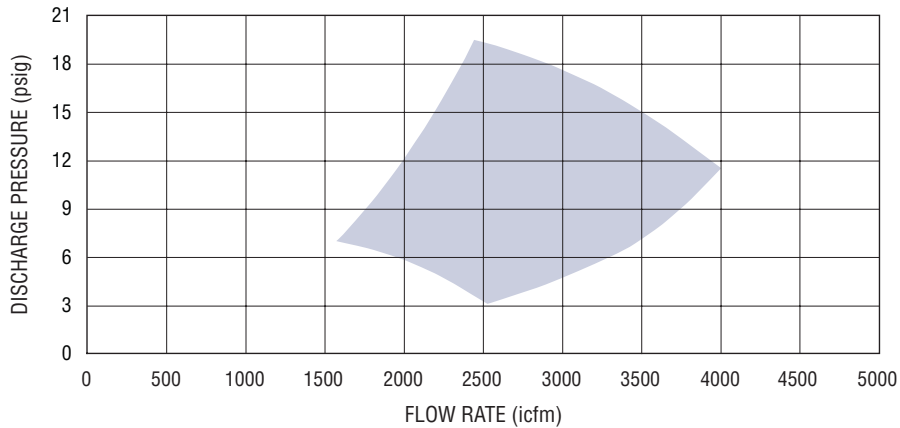

▶ Spencer may make improvements and dimensional changes to equipment designs based on market trends and requirements.

For product selection assistance, please email marketing@spencer-air.com or visit our website at www.spencerturbine.com to locate the Spencer representative in your area.



TECHNICAL DATA SHEET



High speed, high efficiency turbo blower provides energy efficient air delivery

Made in the USA by The Spencer Turbine Company, the AyrJet™ Series 400 is a high speed, high efficiency single-stage turbo blower, driven by a direct drive oil-free permanent magnet motor. It has an integrated variable frequency drive (VFD) with PLC controls.

The product expands Spencer's product offerings for the water and wastewater treatment industries. With flows to 8200 CFM and pressures to 15 PSIG, it handles applications ranging from 300 to 400 HP, includes built-in vibration and temperature monitoring, and features best-in-industry wire to air efficiencies. Built-in inlet filtration is standard, and externally mounted inlet filters are available.

The AyrJet's highly engineered, proven technology magnetic bearings monitor and manage shaft position for proactive protection against catastrophic failure.

Designed especially to meet continuous-duty aeration requirements with peak energy efficiency, the AyrJet™ Series 400 is the ideal solution for applications in municipal wastewater treatment plants.

Materials of Construction

- Casing material: Aluminum 356-T6
- Enclosure material: Carbon steel
- Finish: Powder coated

Product Features

Technical Data

Number of stages: 1
Operating speed: Up to 20,000 RPM
Casing design pressure: 50 PSIG
Inlet connection: Integrated filter (standard); pipe flange (optional)
Outlet connection: 14" flange
Seals: Teflon labyrinth impeller seal
Bearings: <ul style="list-style-type: none"> • Magnetic • Self-monitoring • Non-contact • Built-in power failure back-up protection (UPS system) • 2 modes of fail safe (back-up roller bearing and auto shutdown on fault)
Lubrication: None
Impeller: Machined high strength forged aluminum – 7075-T6 alloy
Dual cooling system: <ul style="list-style-type: none"> • Integrated air cooling • Integrated closed loop 50/50 water-glycol cooling
Filters: Nominal retention 98% @ 15 microns
First critical speed: 20% over maximum operating
Vibration: 0.5 mils

Control System – UL Listed

PLC based with touch-screen and interface to the plant SCADA system <ul style="list-style-type: none"> • Blower system start/stop selection and status indicator • Blower control selection: Local or remote • Blower set-point entry (RPM or SCFM) • Remote signal set point for speed (RPM) and flow (SCFM) • Display status for: <ul style="list-style-type: none"> • Actual blower speed (RPM) and set point • Actual blower flow (SCFM) and set point • Blow-off valve • Blower discharge pressure • Magnetic bearing • Shaft position • Motor winding temperature indicator • VFD and alarm indicator • System vibration alarm indicator

AyrJet by Spencer – The New American Way

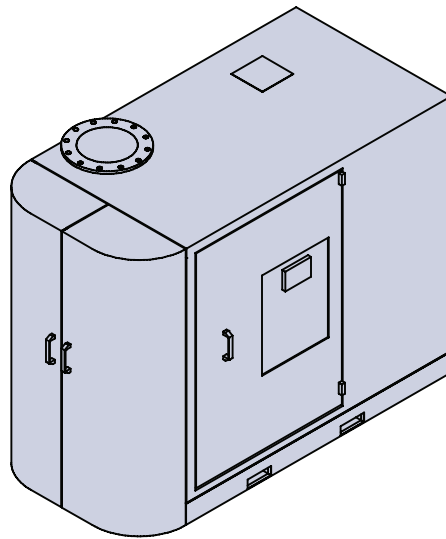
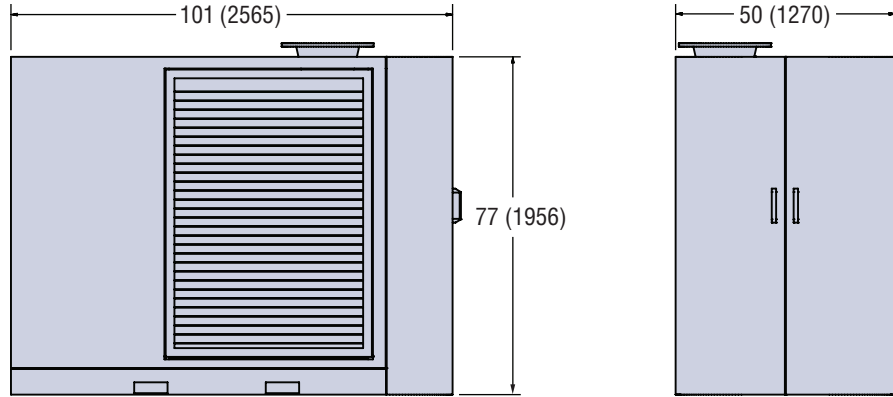

Performance Range

Performance at Standard Conditions

(Air at 68 °F, Relative Humidity of 36%, Inlet Pressure 14.7 psia)

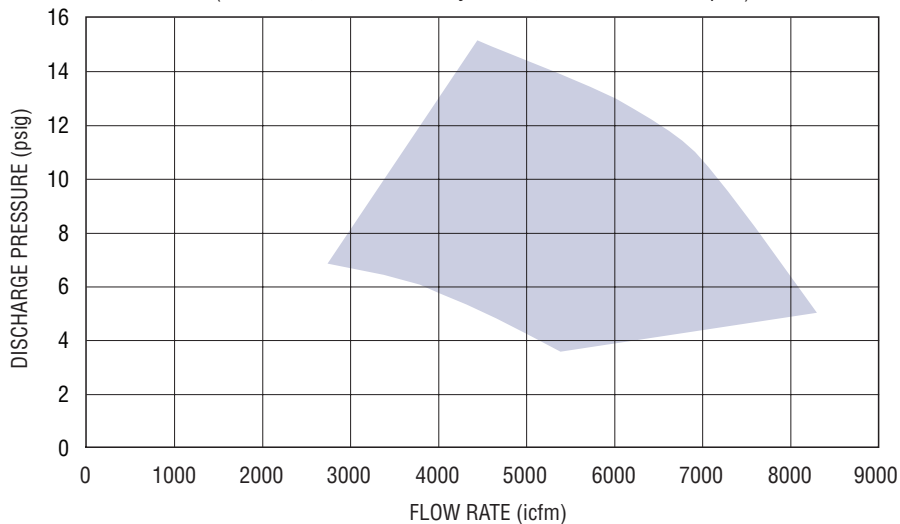

▶ Spencer may make improvements and dimensional changes to equipment designs based on market trends and requirements.

For product selection assistance, please email marketing@spencer-air.com or visit our website at www.spencerturbine.com to locate the Spencer representative in your area.

